

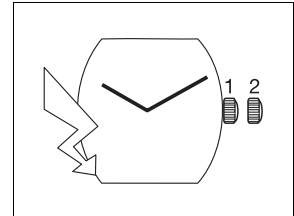

6 3/4" x 8" ETA 802.002

CT 802002 ESI 496069 03 19.03.2010

6 3/4" x 8" Ø 15,30 x 17,80 mm



Movement height	Altura sobre máquina	Altezza sopra movimento	2,95 mm
Height on battery	Altura sobre pila	Altezza sopra pila	3,00 mm
Number of jewels	Número de piedras	Numero di pietre	0
Frequency	Frecuencia	Frequenza	32'768 Hz

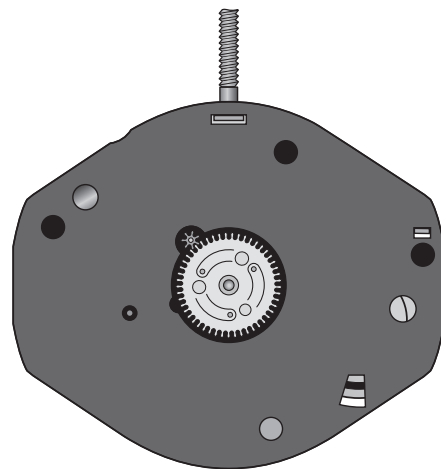
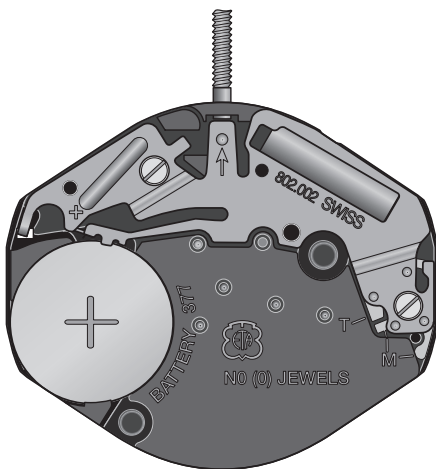

The repair and reconditioning work must only be performed by properly trained personnel.  
Las tareas de reparación y revisión sólo deben ser llevadas a cabo por personal debidamente formado.  
I lavori di riparazione e di revisione devono essere eseguiti esclusivamente da personale adeguatamente formato.



## General information



**Before** starting work, please study this "Technical communication" carefully.



Eye protection is obligatory for all operations / work on the movement!



ETA SA disclaims any liability in case of damage arising from failure to observe this "Technical communication".

## Environmental protection requirements



**The legal provisions relating to waste handling and disposal must be observed in all operations / work on the movement!**

In particular, lubricating and cleaning products harmful to the environment must be disposed of in accordance with the rules!



**Substances prone to cause water pollution** must be stored, transported, collected and disposed of in appropriate vessels.

**Under no circumstances must they pollute the soil or be poured into sewage systems!**

## Explanation of symbols



**Caution! Risk of material damage!**

Below are some obligatory instructions for preventing any material damage!



Below are some instructions for telling which "Specific Information" must be observed.

## Información general



Esta "Comunicación técnica" deberá estudiarse muy bien **antes** de comenzar los trabajos.



Es obligatorio utilizar protección ocular para todos los trabajos en y con el reloj.



ETA SA no se hace responsable de los daños provocados como consecuencia de la inobservancia de esta "Comunicación técnica".

## Normas de protección medioambiental



**Deberá cumplirse la normativa legal relativa al reciclaje y la eliminación correctos de los residuos en todos los trabajos en y con el reloj.**

En especial, deberán eliminarse correctamente los productos lubricantes y de limpieza peligrosos para el medio ambiente.



**Las sustancias contaminantes del agua** deben recogerse, almacenarse, transportarse y eliminarse en recipientes adecuados.

**En ningún caso se permitirá que contaminen el suelo o que lleguen a la canalización.**

## Significado de los símbolos



**Atención Peligro de daños materiales**

Instrucciones que deberán respetarse necesariamente para evitar daños materiales.



Instrucciones para saber qué "Información específica" deberá observarse.

## Informazioni generali



Questa "Comunicazione Tecnica" deve essere studiata attentamente **prima** dell'inizio dei lavori.



Per tutti i lavori su e con il movimento dell'orologio è obbligatorio proteggere gli occhi!



ETA SA declina qualunque responsabilità per eventuali danni causati dalla mancata osservanza della presente "Comunicazione tecnica".

## Disposizioni relative alla protezione ambientale



**Per tutti i lavori su e con il movimento dell'orologio si dovranno rispettare le disposizioni di legge relative al corretto riciclaggio e smaltimento dei rifiuti!**

In particolare si dovrà provvedere al corretto smaltimento di lubrificanti e detergenti nocivi per l'ambiente!



**Le sostanze inquinanti per l'acqua** devono essere conservate, trasportate, raccolte e smaltite in contenitori adatti.

**Queste non devono inquinare il terreno o arrivare nelle canalizzazioni!**

## Spiegazione dei simboli



**Attenzione! Pericolo di danni materiali!**

Seguono importanti indicazioni che devono essere tassativamente rispettate per evitare danni materiali!



Seguono indicazioni su quali "Informazioni specifiche" devono essere rispettate.

## Liste des fournitures - Bestandteilliste - List of components

Pos	No	No CS	Article number Número de artículo Numero articolo	List of components	Lista de piezas	Lista fornitori
1	405	51.020.21	Var	Handsetting stem	Tija de puesta en hora	Albero di messa all'ora
2	4929	20.570.00	7613226038677	Battery	Pila	Pila
			Var	Variante	Variante	Variant

**Interchangeability and variants  
can be found on the  
ETA ONLINE SHOP (EOS):**

**www.eta.ch**  
→ Customer Service  
→ Customer Service Portal

**La intercambiabilidad y las  
variantes se encuentran en  
ETA ONLINE SHOP (EOS):**

**www.eta.ch**  
→ Customer Service  
→ Customer Service Portal

**L'intercambiabilità e le varianti si  
trovano sul  
ETA ONLINE SHOP (EOS):**

**www.eta.ch**  
→ Customer Service  
→ Customer Service Portal

Materials - Fornituras - Forniture



1 Var

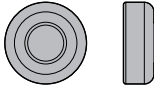

2

Spare parts - Piezas de repuesto - Pezzi di ricambio:



**Movement undivisible !**  
**Movimiento no desmontable !**  
**Movimento non smontabile !**



- see IS 58.  
- ver IS 58.  
- vedere IS 58.

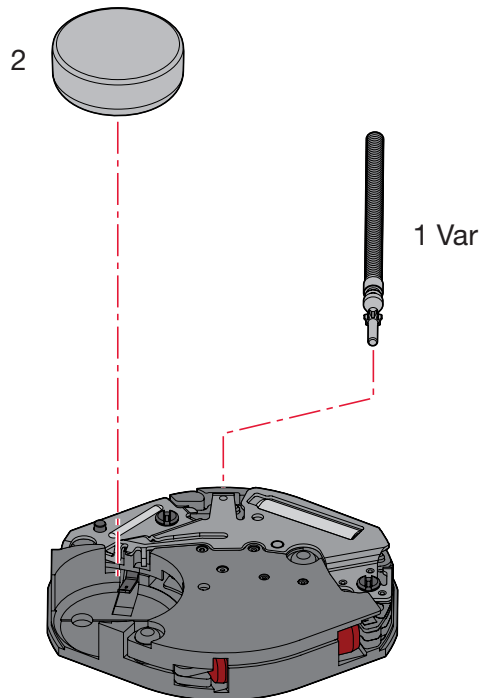

## Electrical tests - Controles eléctricos - Controlli elettrici

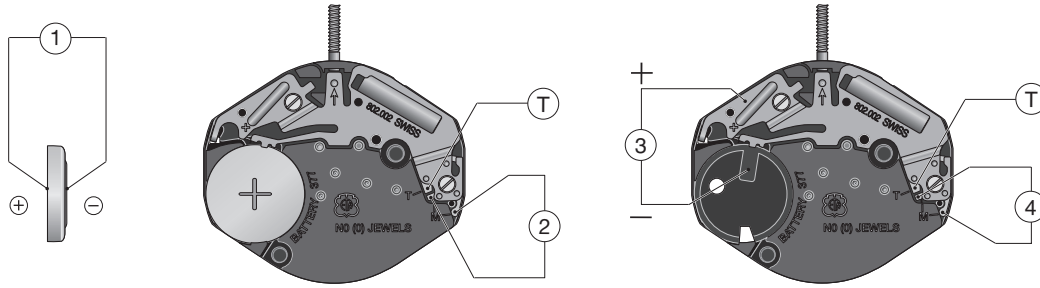

Position Posición Posizione	Setting of apparatus Escala de medición Scala di misura	Measurement Medición Misura	Test Control Controllo	Remarks Notas Osservazioni
1	2 V ( $R_i \geq 10 \text{ k}\Omega/\text{V}$ )	1,55 V	Battery voltage. Tensión de la pila. Tensione della pila.	
2	1 V ( $R_i \geq 10 \text{ k}\Omega/\text{V}$ )	Hand of measuring apparatus oscillates in + and - : 1/s. La aguja del multimetro oscila en sentido + y - : 1/s. La lancetta del multimetro oscilla nel senso + e - : 1/s.	Impulse at output of integrated circuit. Impulsos a la salida del circuito integrado. Impulsi all'uscita del circuito integrato. 1/s	Measurement with controlled battery. Medición con una pila controlada. Misura con una pila controllata.
3	2 V	$\leq 1,30 \text{ V}$ Connect the test point T to the negative pole of the external power supply. Conectar el punto de prueba T con el polo menos de la alimentación externa. Collegare il punto test T con il polo meno dell'alimentazione esterna.	Lower working-voltage limit. Límite inferior de la tensión de funcionamiento. Limite inferiore della tensione di funzionamento.	Measurement without battery, with variable external power supply, starting with 1,55 V, lower tension until movement stops. Medición sin pila, con alimentación exterior variable. Bajando de 1,55 V hasta la parada del movimiento. Misura senza pila, con alimentazione esterna variable, scendendo da 1,55 V fino all'arresto del movimento.
	10 $\mu\text{A}$	$\leq 1,30 \mu\text{A}$ Motor driven with 16 steps/s. Motor impulsado por 16 pasos/s. Comando motore a 16 passi.	Consumption of movement with stem in neutral position, at 1,55 V. Consumo del movimiento con la tija en posición neutra, en 1,55 V. Consumo del movimento con albero in posizione neutrale a 1,55 V.	Measurement without battery, with external power supply 1,55 V. Medición sin pila con alimentación exterior de 1,55 V. Misura senza pila con alimentazione esterna di 1,55 V.
4	• 10 k $\Omega$	0,80–1,10 k $\Omega$	Condition of coil. Estado de la bobina Continuità della bobinatura.	
	<p><i>Ohmmeter with a test voltage exceeding 0.40 V unsuitable, recommended voltage 0.20 V.</i>                      • <i>Ohmiómetros con tensión de medición superior a 0,40 V inapropiados; tensión recomendada 0,20 V</i>  <i>Ohmmetri con tensione di misura superiore a 0,40 V sono inadeguati; tensione raccomandata 0.20 V</i></p>			

*The test must be conducted at an ambient temperature of between 20°C and 25°C.  
 Las pruebas deben realizarse a una temperatura ambiente comprendida entre 20°C y 25°C.  
 I test devono essere effettuati a temperatura ambiente compresa tra 20°C e 25°C.*

Ajustement aiguille des heures  
Stundenzeigerpassung  
Hour hand fitting

Ajustement aiguille des minutes  
Minutenzeigerpassung  
Minute hand fitting

Ajustement aiguille des secondes  
Sekundenzeigerpassung  
Second hand fitting

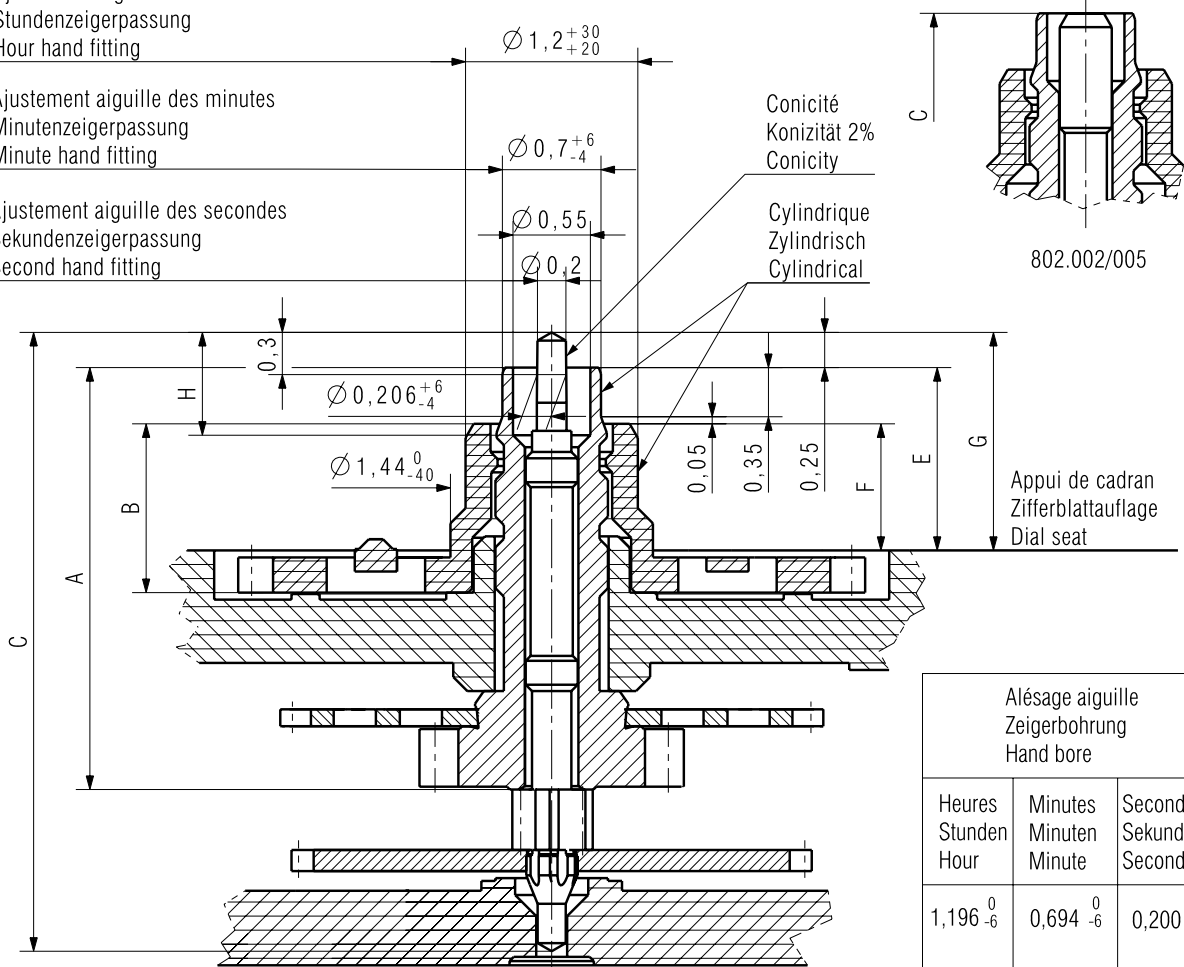

Alésage aiguille Zeigerbohrung Hand bore		
Heures Stunden Hour	Minutes Minuten Minute	Secondes Sekunden Second
1,196 <sup>0</sup> <sub>-6</sub>	0,694 <sup>0</sup> <sub>-6</sub>	0,200 <sup>0</sup> <sub>-6</sub>

Aiguillage Zeigerwerkhöhe Hand fitting height	Longueur/Länge/Length			Dépassement Höhe über Zifferblattauflage Height over dial seat				Ep.cadran Zifferblattdicke Dial thickness
	A	B	C	E	F	G	H	
2	3	1,2	4,4	1,3	0,9	1,55	0,73	
2	3	1,2	4,15	1,3	0,9	sans sek: ohne sek: without sek: CAL802.002/005		
Aiguilles Zeiger Hands				Aiguille des heures Stundenzeiger Hour hand	Aiguille des minutes Minutenzeiger Minute hand	Aiguille des secondes Sekundenzeiger Second hand		
Masse/Masse/Mass	max.			mg	20	10	10	
Balourd/Unwucht/Unbalance	max.			µNm	0,6	0,6	0,1	
Force de chassage Setzkraft Press in force	max.			N	30	30	30	
Kaliber / Calibre / Caliber 802.102/105 802.002/005					Masstab Echelle Scale --	 Masse in mm Dimensions en mm Dimensions in mm Tol. 1/1000 mm		
AIGUILLAGES ZEIGERWERKHÖHEN HAND FITTING HEIGHTS					Z0033543	Version 07	Revision 00	Blatt Feuille Sheet 01/01
 <b>ETA SA</b> MANUFACTURE HORLOGÈRE SUISSE DEPUIS 1793  A COMPANY OF THE SWATCH GROUP				Ersatz für/En remplacement de/Remplacement for Aenderung/Modification 22932		Klass. ZVACC Erstellt Etabli Created 13.11.2007 PUC		KUN Geprüft Contrôlé Controlled 13.11.2007 BMA Freigegeben Libéré Released 14.11.2007 FEU

We reserve all rights for this document. It is meant for the recipient only and it may not be copied, printed or given to a third person without our written permission. Quedan reservados todos los derechos relacionados con este documento. Queda por lo tanto prohibida su copia, impresión o cualquier otra autorización por escrito. Ogni diritto su questo documento è riservato. Il documento è indirizzato esclusivamente al destinatario e non può essere copiato, stampato o ceduto a terzi senza un'autorizzazione scritta.

**Modifications compared with previous document versions****Modificaciones comparadas con las versiones anteriores del documento****Modifiche comparate con le versioni precedenti del documento**

Version Versión Versione	Date Fecha Data	Modification	Modificación	Modifica	Page Página Pagina
03.1	19.03.2010	Text correction	Corrección texto	Correzione testo	3
03	18.03.2010	Spare parts	Piezas de repuesto	Pezzi di ricambio	3-5
02	03.11.2009	New layout	Nuevo layout	Nuova layout	1-8
		Allocation per caliber	Asignación por calibres	Ripartizione per calibri	--

All modifications reserved.

Salvo modificación.

Con riserva di ogni eventuale modifica.

This document can be found on the  
Customer Service Portal (CSP):

[www.eta.ch](http://www.eta.ch)

- Customer Service
- Customer Service Portal
- Technical Documents

Este documento se encuentran en el  
Customer Service Portal (CSP):

[www.eta.ch](http://www.eta.ch)

- Customer Service
- Customer Service Portal
- Technical Documents

Il presente documento si trovano sul  
Customer Service Portal (CSP):

[www.eta.ch](http://www.eta.ch)

- Customer Service
- Customer Service Portal
- Technical Documents



**ETA**<sup>SA</sup>  
MANUFACTURE HORLOGÈRE SUISSE  
DEPUIS 1793

## CUSTOMER SERVICE

Bahnhofstrasse 9  
P.O. Box 359  
2540 Grenchen  
Switzerland

Phone +41 (0)32 655 27 77  
Fax +41 (0)32 655 84 30

etacs@eta.ch  
[www.eta.ch](http://www.eta.ch)